

Haloview

Model No.: CA112

Functions of each part

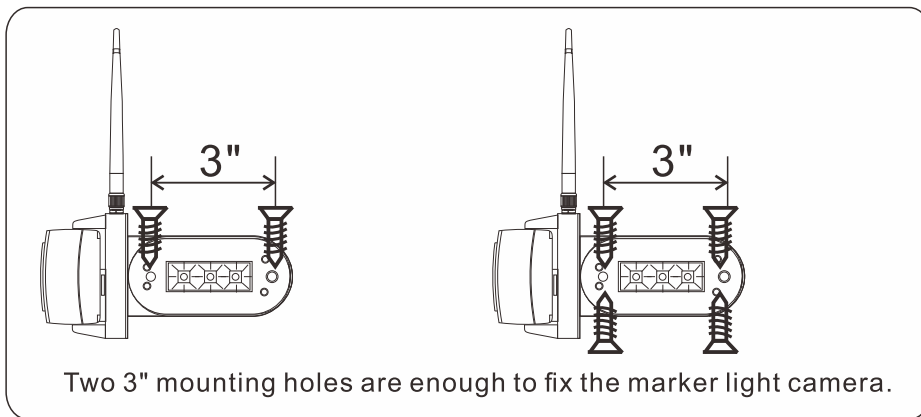
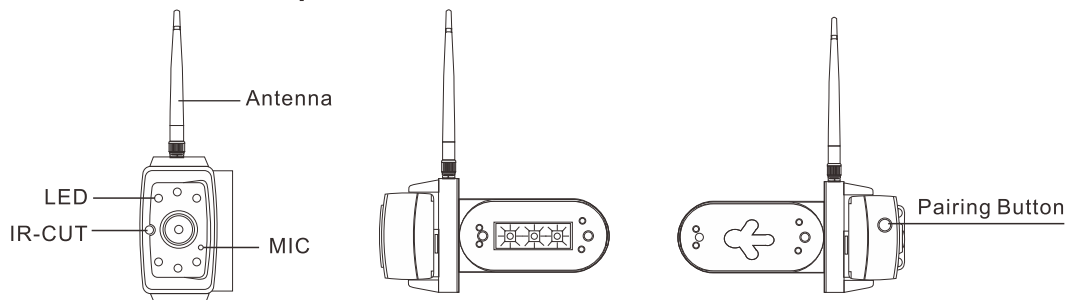

Installation

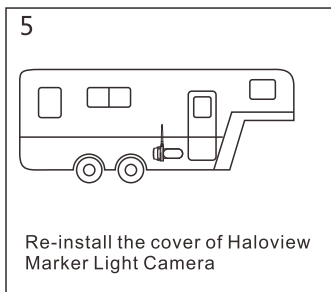
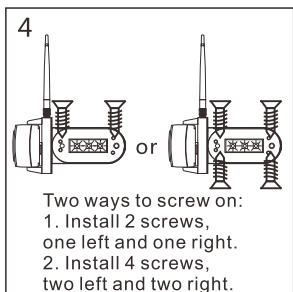
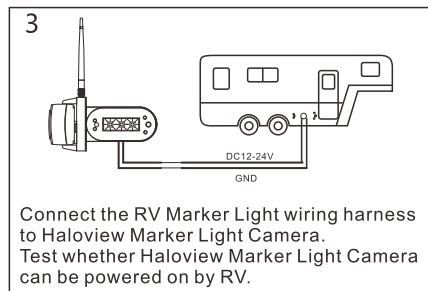
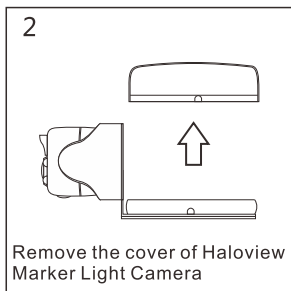
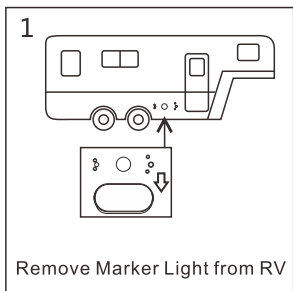

CAMERA SPECIFICATION

Model NO.: CA112

Image Device	1/4" CMOS	
TV System	25fps	30fps
Effective Pixels	1280×720 pixels	
Pixel Size	3.0um×3.0um	
Video Output	8bits YUV	
Scanning System	Progressive Scanning	
Sync. System	Internal	
Gamma Consumption	0.45	
AGC	Auto	
White Balance	Auto	
BLC	Auto	
Electronic Shutter	Electronic Rolling Shutter	
Operation Frequency	2412-2467MHz	
Transmission Distance (barrier free)	300m(984ft)	
Transmission Power	18dBm	
Video Codec	H.264	
Spread Spectrum	DSSS	
Latency	200ms	
RF Bit Rate	12Mbps	
Minimum Illumination	0Lux	
Power Supply	DC12-24V	
Night vision distance	8~10m	
Waterproof rating	IP69K	
Viewing Angle	120°	
Audio	Yes	
SMART-IRCut	Yes	
Operating Temperature	-20°C ~ 70°C, RH95%MAX	
Storage Temperature	-30°C ~ 80°C, RH95%MAX	

⚠ Special Notice

To prevent water leakage into RV from the maker light camera screw holes, please glue the screw holes by glass cement.

